

MR-J2-Super Series

A Series of the most Advanced Servo Driver/Motor ❖



Features

- High-performance CPU incorporated for improved response
 - The application of a high-performance CPU has enhanced response significantly. Speed loop frequency response raised to 550Hz.
- High-resolution Encoder 131072p/rev (17bit)
 - The inclusion of a high-resolution encoder ensures high performance and safety at low speeds. Motor sizes are the same as previous products and wiring is compatible.
- HC-KFS series: Miniaturized, low-inertia motor
- HC-SFS series: Medium capacity, medium-inertia motor

Overseas Standards & Environmental Safety

EN Standards

Servomotor and amplifier both correspond to standards specifications for low-voltage directives (LVD). An EMC filter is available for meeting EMC directives.

UL/cUL Standards

In accordance with UL and CSA standards, products qualified as meeting cUL standards are considered to meet CSA standards. Both the servomotor and amplifier meet these standards specifications.

IP65 Application

The HC-SFS 2000r/min and 3000r/min series servomotors conform to IP65 standard. (The HC-SFS 2000r/min series can conform to IP67 standard.) The HC-KFS series of servomotors meet IP55 standard (with conformance to IP65 standard possible). These models have been improved compared to existing models for the environment.

Enhanced Tuning Technology for Ease of Use

Auto-tuning Performance Improved

Even when acceleration/deceleration torque is short or friction on the vertical axis is large, the load inertia moment is adjusted to the optimum value automatically.

Auto-tuning

- Comparison of Estimated and Actual Server Load Inertia Moment
Example: HC-KFS13, ball screw, load inertia moment ratio 5.6 times, vertical axis unbalance load of 20%, friction torque of approx. 15%, acceleration/deceleration torque 1.4% of rated value.

HC-KFS13 Previous Auto-tuning

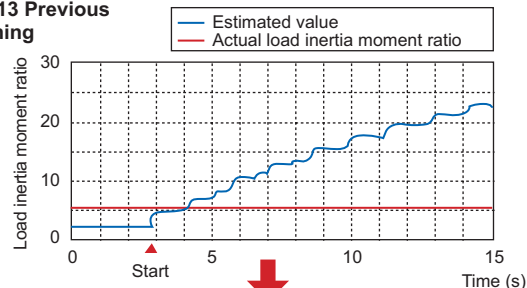

HC-KFS13 Advanced Real-time Auto-tuning

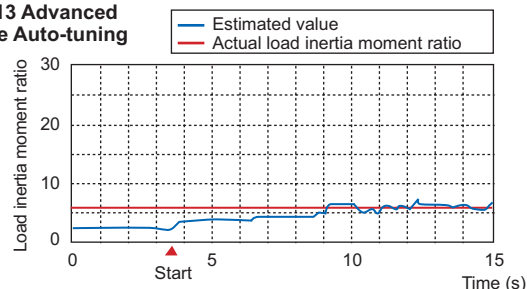

Adaptive Vibration Suppression Control Function

All servo systems performance are restricted by machine resonance. This adaptive vibration suppression control function breaks this barrier to give further stability at higher response.

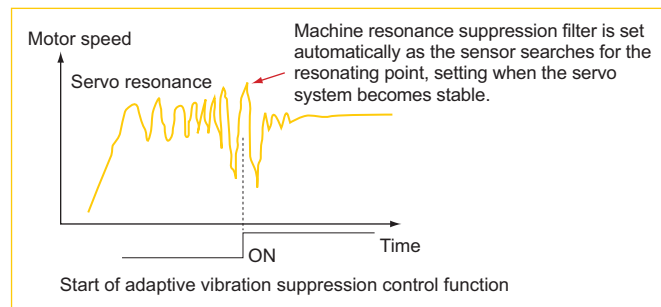

Machine Resonance Suppression Filter

Two points can be set to match the machine resonating point. This filter can be combined with the adaptive vibration suppression control function as well, however, only one point can be set for the machine resonance suppression filter at that time.

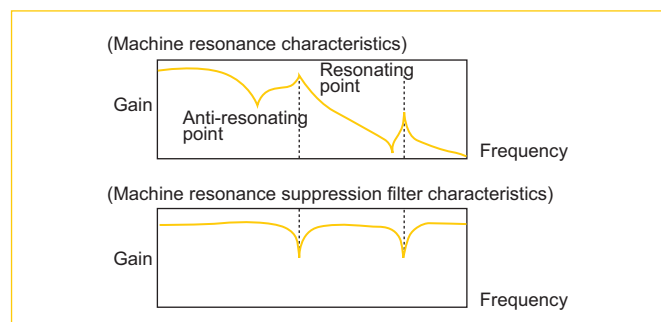

Model Configurations

Servo-amp

MR-J2S-10 A

MELSERVO-J2-Super Series

A: General pulse train interface
B: SSCNET

◆ Conforms to following standards: EN, UL, cUL

Compatible motor output capacity (kW)

| Symbol | HC-KFS | HC-SFS |
|--------|---------|------------------------------|
| 10 | 053, 13 | — |
| 20 | 23 | — |
| 40 | 43 | — |
| 60 | — | 52, 53 |
| 70 | 73 | — |
| 100 | — | 81, 102, 103 |
| 200 | — | 121, 201, 152, 202, 153, 203 |
| 350 | — | 301, 352, 353 |
| 500 | — | 52 |
| 700 | — | 702 |

Servomotor

HC-KFS 05 3 B

| Symbol | Motor Series |
|--------|---------------------------------|
| K | Low inertia, small capacity |
| S | Medium inertia, medium capacity |

◆ Conforms to following standards: EN, UL, cUL

17bit encoder for use in absolute and incremental systems (serial encoder)

| Symbol | Rated output capacity (kW) |
|----------|----------------------------|
| 05 | 0.05 |
| 1 to 8 | 0.1 to 0.85 |
| 10 to 70 | 1.0 to 7.0 |

| Symbol | Electromagnetic brake |
|--------|-----------------------|
| None | — |
| B | Installed |

| Symbol | Axial end |
|--------|------------------|
| None | Standard |
| K | Key way (Note 1) |
| D | D-cut (Note 2) |

Note:
1. HC-KFS□K model of 200W or more have key.
2. The D-cut is available only for the HC-KFS model of 100W or less.

| Symbol | Rated speed (r/min) |
|--------|---------------------|
| 1 | 1000 |
| 2 | 2000 |
| 3 | 3000 |

Servomotor Models & Features

| Motor series | Rated speed (Max.) (r/min) | Rated output capacity (kW) | Servomotor type | Protective degree | Feature | Application examples |
|---------------|--|--|-------------------------------|--|---|--|
| | | | With electromagnetic brake(B) | | | |
| HC-KFS series | 3000 (4500) | 4 types 0.05, 0.1, 0.2, 0.4, 0.75 | ○ | IP55 Excluding the shaft-through portion and connector (IP65) | Low inertia Large motor inertia moment makes this unit well suited for machines with fluctuating load inertia moment or machines with low rigidity such as conveyors. | * Semiconductor machinery * Robots * Mounters * Sewing machines * X-Y tables * Food processing machines |
| HC-SFS series | 1000 (1500: 0.85kW) (1200: 1.2~3kW) | 4 types 0.85, 1.2, 2.0, 3.0 | ○ | IP65 (IP67) | Medium inertia Suitable for variable applications three models from low to high-speed are available. | * Conveyor machines * Robots * X-Y tables |
| | 2000 (3000: 0.5~1.5kW) (2500: 2, 3.5kW) (2000: 5, 7kW) | 5 types 0.5, 1.0, 1.5, 2.0, 3.5, 5.0, 7.0 | ○ | IP65 (IP67) | | |
| | 3000 (3000) | 5 types 0.5, 1.0, 1.5, 2.0, 3.5 | ○ | IP65 (IP67) | | |

▣ Servo-amp Specifications

| Servo-amp model MR-J2S- □ A/B | | 10 | 20 | 40 | 60 | 70 | 100 | 200 | 350 | 500 | 700 | |
|--------------------------------|------------------|--|---|----|----|----|--------------------------------|-----|-----|-----|-----|--|
| Power supply voltage/frequency | | 3-phase 200 to 230V AC 50/60Hz or 1-phase 230V AC 50/60Hz | | | | | 3-phase 200 to 230V AC 50/60Hz | | | | | |
| Control system | | Sine-wave PWM control/current control system | | | | | | | | | | |
| Speed frequency response | | 550Hz or more | | | | | | | | | | |
| A type | Position control | Pulse input | 500K (Differential) 200K (Open Collector) | | | | | | | | | |
| | | Pulse feedback | 131072 pulse/Revolution | | | | | | | | | |
| | | Electronic gear | 1/50<A/B<500 | | | | | | | | | |
| | Velocity control | Voltage input | DC 0~ ±10V | | | | | | | | | |
| | | Control range | 1:2000 (External) / 1:5000 (Internal) | | | | | | | | | |
| | Torque control | Voltage input | DC 0~ ±8V | | | | | | | | | |
| B type | Position control | SSCNET input 32 bit command | | | | | | | | | | |

▣ HC-KFS series servomotor Specifications

| Servomotor series | | HC-KFS series (small capacity, low inertia) | | | | |
|---|----------------------------|---|---------------|--------------|--------------|------------|
| Models | Servomotor model HC- | KFS053(B) | KFS13(B) | KFS23(B) | KFS43(B) | KFS73(B) |
| Specifications | Servo-amp model MR- | J2S-10A/B | | J2S-20A/B | J2S-40A/B | J2S-70A/B |
| Power facility capacity (kVA) (*) | | 0.3 | 0.3 | 0.5 | 0.9 | 1.3 |
| Continuous running duty | Rated output (kW) | 50 | 100 | 200 | 400 | 750 |
| | Rated torque (N·m [oz·in]) | 0.16 (22.7) | 0.32 (45.3) | 0.64 (90.6) | 13 (184.1) | — |
| Maximum torque (N·m [oz·in]) | | 0.48 (68.0) | 0.95 (134.5) | 1.9 (269.0) | 3.8 (538.1) | — |
| Rated rotation speed (r/min) | | 3000 | | | | |
| Maximum rotation speed (r/min) | | 4500 | | | | |
| Rated current (A) | | 0.83 | 0.71 | 1.1 | 2.3 | — |
| Moment of inertia J (x10 ⁴ kg·m ²) [J (oz·in ²)] | | 0.053 (0.29) | 0.084 (0.459) | 0.42 (2.296) | 0.67 (3.663) | — |
| Weight kg (lb) | | 0.4 (0.88) | 0.53 (1.17) | 0.99 (2.18) | 1.45 (3.20) | 3.0 (6.61) |

(*): The power facility capacity varies depending on the power supply's impedance.

▣ HC-SFS series servomotor Specifications

| Servomotor series | | HC-SFS 3000 series (medium capacity, medium inertia) | | | | |
|---|----------------------------|--|---------------|---------------|---------------|---------------|
| Models | Servomotor model HC- | SFS53(B) | SFS103(B) | SFS153(B) | SFS203(B) | SFS353(B) |
| Specifications | Servo-amp model MR- | J2S-60A/B | J2S-100A/B | J2S-200A/B | | J2S-350A/B |
| Power facility capacity (kVA) (*) | | 1.0 | 1.7 | 2.5 | 3.5 | 5.5 |
| Continuous running duty | Rate output(kW) | 0.5 | 1.0 | 1.5 | 2.0 | 3.5 |
| | Rated torque (N·m [oz·in]) | 1.59 (225.1) | 3.18 (450.3) | 4.78 (676.8) | 6.37 (901.9) | 11.1 (1571.6) |
| Maximum torque (N·m [oz·in]) | | 4.77 (675.4) | 9.55 (1352.3) | 14.3 (2024.8) | 19.1 (2704.5) | 33.4 (4729.3) |
| Rated rotation speed (r/min) | | 3000 | | | | |
| Maximum rotation speed (r/min) | | 3000 | | | | |
| Rated current (A) | | 3.2 | 5.3 | 8.6 | 10.4 | 16.4 |
| Moment of inertia J (x10 ⁴ kg·m ²) [J (oz·in ²)] | | 6.6 (36.1) | 13.7 (74.9) | 20.0 (109) | 42.5 (232) | 82.0 (448) |
| Weight kg (lb) | | 5 (11) | 7 (15.4) | 9 (19.8) | 12 (26.5) | 19 (41.9) |

(*): The power facility capacity varies depending on the power supply's impedance.

System Block Diagram

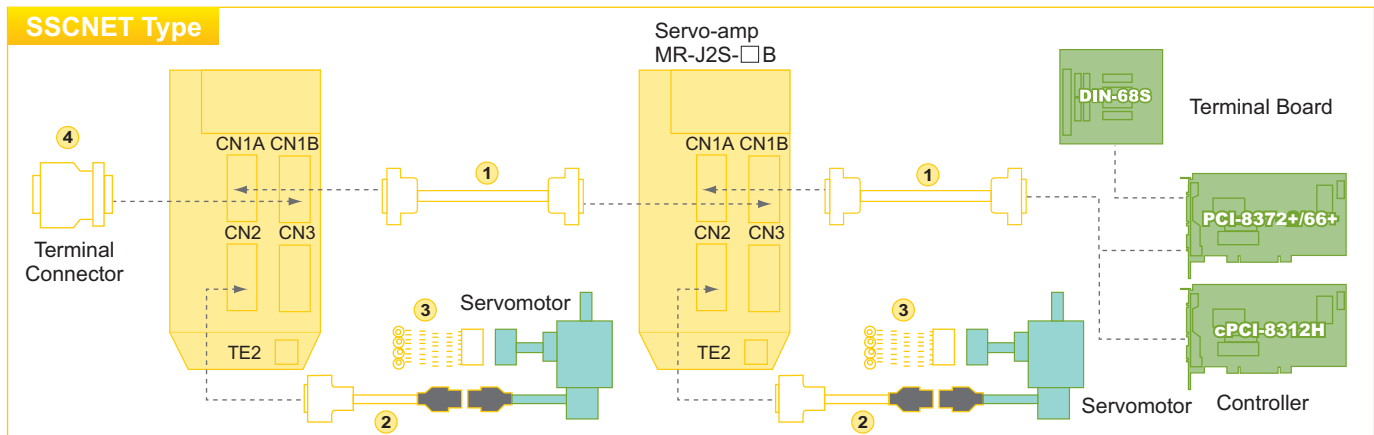
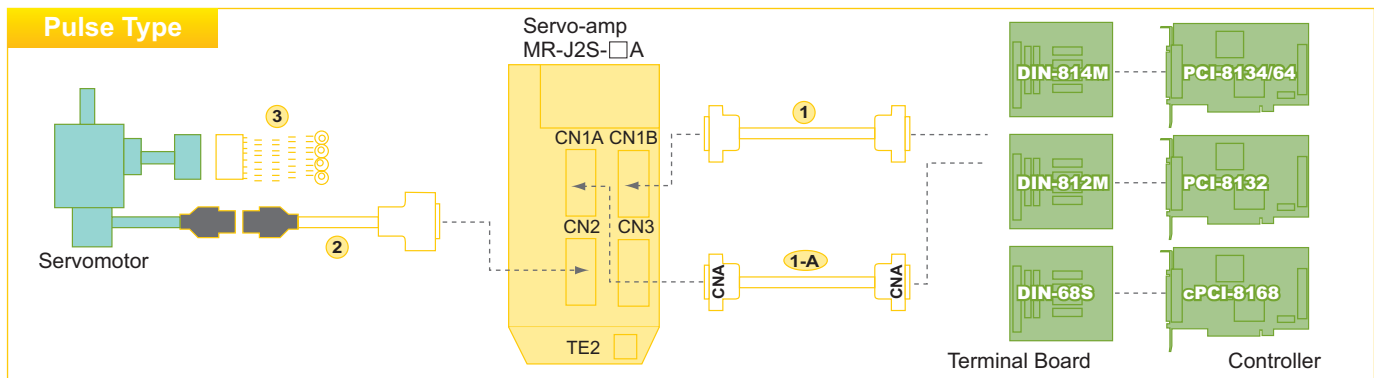

* Refer to Accessory Selection Guide

Controller & Terminal Board Selection Guide

| Mode | Amplifier | Motion Board | Terminal Board |
|--------|-----------|-----------------|----------------|
| Pulse | MR-J2S-□A | PCI-8132 | DIN-812M |
| | | PCI-8134/8164 | DIN-814M |
| | | cPCI-8168 | DIN-68S/2 |
| SSCNET | MR-J2S-□B | PCI-8372+/8366+ | DIN-68S/2 |
| | | cPCI-8312H | DIN-68S/2 |

Accessory Selection Guide

| Accessory item | Motor | |
|--------------------------------|---|---|
| | KFS Series | SFS Series |
| ① Controller to amp. bus cable | MR-J2HBUS□M | |
| ①-A MR-J2HBUS□M (CNA) | | |
| ② Encoder cable | MR-JCCBL□M | MR-JHSCBL□M |
| ③ Power supply connector | (1) MR-PWCNK1 | (1) MR-PWCNS1/2/3 |
| | (2) MR-PWCNK2 (for the motor with brake) | (2) MR-BKCN (for the motor with brake) |
| ④ Terminal connector | MR-A-TM (for MR-J2S-□B series) | |

□ = cable length: 2 meter/5 meter

Ordering Information

| Servomotor | KFS053 | KFS23 | KFS43 | KFS73 | SFS102/103 | SFS152/153 | SFS352/353 | SFS502 | SFS702 |
|------------|--|-------|-------|-------|------------|------------|------------|--------|--------|
| SFS□(B) | | | | | | SFS202/203 | | | |
| KFS□(B) | | | | | | | | | |
| Amplifier | | | | | | | | | |
| MR-J2S- | 10A/B | 20A/B | 40A/B | 70A/B | 100A/B | 200A/B | 350A/B | 500A/B | 700A/B |
| Accessory | Please see the Accessory Selection Guide | | | | | | | | |